

Light Grey, Brown

Matting materials have a tendency to shrink slightly when first unrolled. In applications where length is critical, allow the material to relax for at least 4 hours before cutting to size. Always trim with a sharp knife or razor blade.

Disclaimer:

All statements, technical data, and recommendations contained herein are based upon tests we believe to be reliable. However, the accuracy or completeness thereof is not guaranteed. The proper and correct applications of products and data is the responsibility of the user. Statements or recommendations not contained herein shall have no force or effect unless embodied in a written agreement signed by authorized offers of Desco Industries, Inc.

Description:

Statfree S™ material is specifically designed to reduce fatigue in areas where standing is required for long periods of time. This floor mat combines ESD protection and durability. The heavy embossed texture provides slip and soil resistance. Statfree S™ is available with an additional feature of a yellow warning stripe on the edges. It meets the requirements of DOD-HDBK-263, DOD-STD-2000, ESD-S7.1 and EN 100 015 Issue 1.

Electrical Properties:

Property	Test Method	Value
RTG Resistance:	ESD S7.1	10E9 - 10E10 Ohms
RTT Resistance:	ESD S7.1	10E9 - 10E10 Ohms

Electrical Properties obtained by testing to industrial standards by an independent testing laboratory @ 100 Volts and 50% relative humidity unless otherwise specified. Complete text of the test report is available upon request.

Specifications:

- Construction: Foamed Homogeneous Vinyl electrical properties consistent throughout. Designed specifically to reduce fatigue as a standing surface.
- Thickness: 0.375 inches (9.5mm)
- Texture:* Non-directional, heavy embossed, soil and abrasion resistant
- Color:* Light grey, brown
- Weight: 0.65 lbs/ft² (0.317g/cm²)
- Hardness: ASTM-D-2240-75 65 Shore "00"
- Wear Resistance: Negligible-Tabor Abrader, 500 Cycles CS-17 wheels, 10,000 grams load
- Heat Resistance: -20°F to 140°F continuous

*Color and texture may vary between lots and mills

Grounding: This material must be properly grounded for optimum electrical performance. Ask for Tech Brief PS-2013 for mat grounding instructions.

Cleaning: For optimum electrical performance, surface must be cleaned regularly using an ESD mat cleaner. We suggest using our Reztore™ Surface & Mat Cleaner Item #16030 or Static-Wipes Item #16020. Do not use cleaners with silicone. Silicone buildup will create an insulative film on the surface.

See reverse side for available mat and roll sizes.

RoHS Compliance Statement

None of the following materials are intentionally added in manufacturing this product: lead, mercury, cadmium, hexavalent chromium, polybrominated biphenyls (PBB) or polybrominated diphenyl ethers (PBDE) as outlined in the Directive 2002/95/EC Article 4.1. See Desco Industries Inc. letter on-line at ESDSystems.com.

Limited Lifetime Warranty:

ESD Systems warrants for one year that Statfree® matting products will be free of defects in materials and workmanship and will guarantee dissipative/conductive mat properties for the life of the mat. Damage to matting caused by misuse of any kind, including using inappropriate cleaners is not covered by ESD Systems Limited Warranty.



Made in America

Statfree S™ Floor Mat, Vinyl, Homogeneous, Antifatigue, 0.375" (9.5mm)



ESD SYSTEMS.COM
432 NORTHBORO ROAD CENTRAL
MARLBORO, MA 01752 USA
TEL. (508) 485-7390 FAX (508) 480-0257



Visit our online library of Tech Drawings:
<http://www.esdsystems.com>

**Drawing: TD-S
Material Statfree S™**

**DATE
12/05**

Item Number Reference For Statfree S™ Vinyl, Homogeneous, Antifatigue

MATS



BEVELED ON ALL EDGES

Mat Size: 3' x 5'

Kit Item Numbers

COLOR	ITEM NO.
BROWN	11101
GREY	11111

Tolerances:
 Width ± .250"
 Length ± .250" every 1 linear foot of running material.

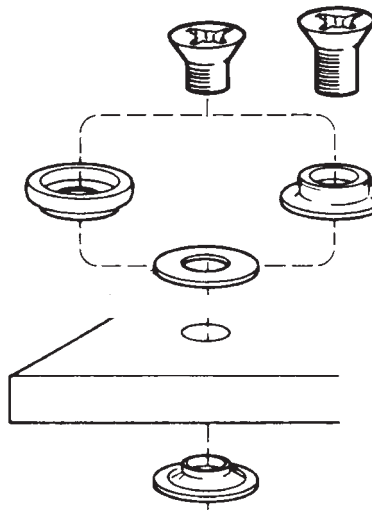

For best results use 12000 Universal Screw-on snap kit with Statfree S™ Foamed Vinyl.

ROLL STOCK

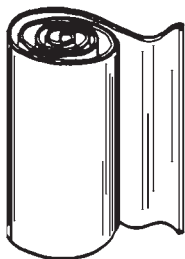

Hardware is not included with rolls.

.375" (9.5mm)
THICK ROLLS

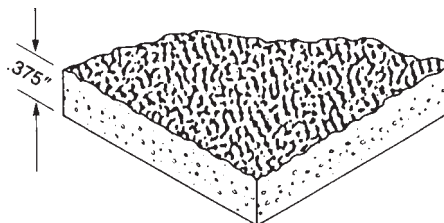

Roll Stock Item Numbers

COLOR	ITEM NO.	APPROX. WT.
BROWN	11105	130 lb.
GREY	11115	130 lb.

Roll Stock Size 3' x 60'
 (Roll Stock beveled on sides only)

As a general rule, continuous runs of ESD matting should be grounded at ten-foot intervals to ensure path-to-ground and not substantially increasing RTG. Each individual ESD mat should be grounded with ground snap located no further than five feet from either end.

