

Touch Tester - Operation, Installation and Calibration Instructions



Made in America

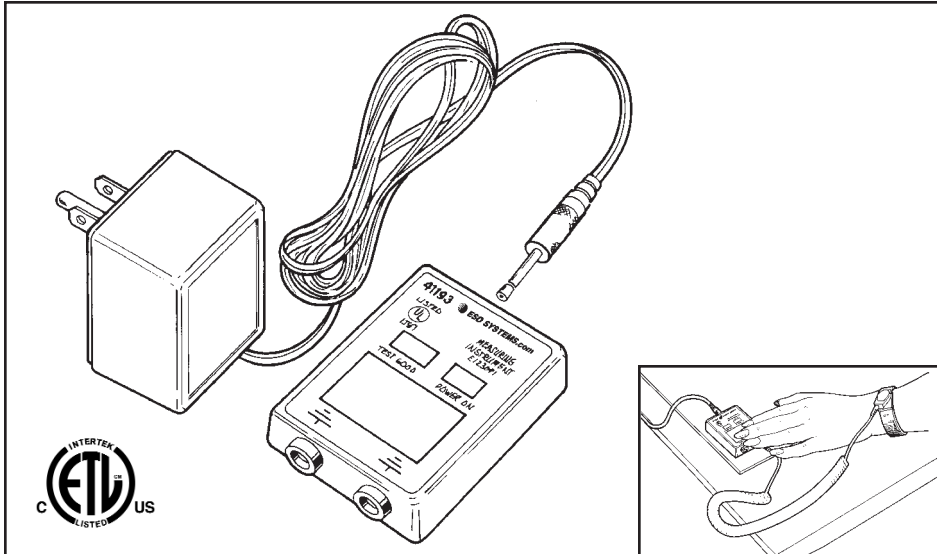

Figure 1. Model 41193 Wrist Strap Touch Tester / Common Point Ground

Description

Per ANSI/ESD S20.20, test equipment is required to enact Compliance Verification Plan Requirement. Test equipment shall be selected to make measurements of appropriate properties of the technical requirements that are incorporated into the ESD program plan.

This ESD Systems.com product is an “on demand” wrist strap tester that also functions as a common-point ground for two wrist straps and a mat. Model 41193 operates on 120 VAC, 50-60 Hz. The pass range for model 41193 is 750K to 10 Megohms.

When the wearer of a wrist strap touches the metallic surface of the wrist strap tester, a path for current flow is completed from the wearer’s skin, through the wrist strap, to the metallic surface to ground. This action will cause the green “test good” LED to light (and the optional audible signal to sound) as long as the resistance of the circuit path is between 750k Ohms and 10 Megohms.

The wrist strap being tested may be plugged directly to the tester or any

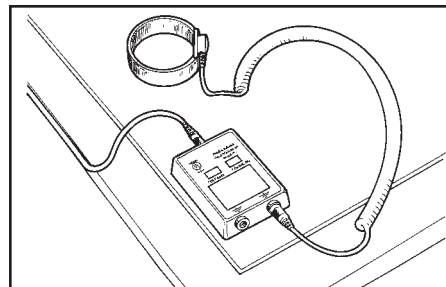

Figure 2. 41193 Testing Circuit

convenient common ground point. The wrist strap will test properly as long as both the wrist strap tester and the wrist strap are connected to a common ground. Therefore, any number of wrist strap wearers may use the wrist strap tester if they can conveniently reach it. ESD Systems.com item 13525 wrist strap bench ground provides two banana jacks for grounding wrist straps.

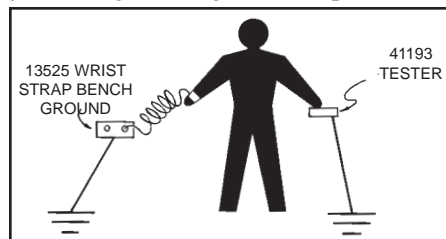

Figure 3. Testing a wriststrap

When the wrist strap tester and a 13525 are tied to a common ground (utility ground) wrist straps plugged into the 13525 can also be tested.

Installation

The wrist strap tester is easily attached at the workstation. A snap stud at ground reference is provided on the back of the unit, allowing it to be snapped directly to a mat. In this configuration, the unit provides a common-point ground for both the mat and the wrist strap, and is easily accessible for frequent testing. A piece of adhesive backed hook and loop fastener is provided for the users who wish to have a more secure mount.

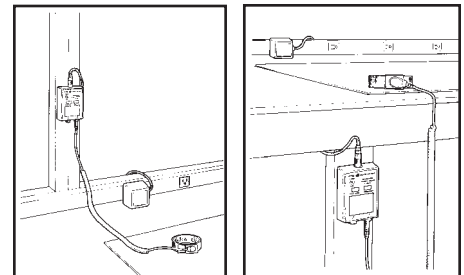

Figure 4. Installation of Tester

The hook-and-loop type fastener also allows fast mounting to smooth surfaces. This method is convenient for mounting the tester on a workstation leg or on an upright support for shelving or lights. (Note - the snap does not have to be connected for proper grounding).

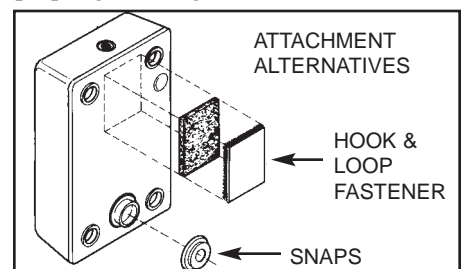

Figure 5. Attachment Alternatives.

Equipment Rating:

AC Adapter rated 120 Vac, 60 Hz, 6 W.
Ground Touch Tester rated 6.5 Vdc, 50 mA.

Environmental Conditions

- Suitable for indoor use only at altitudes not exceeding 6500 ft. (2Km)
- Temperature range of 41°F (5°C) to 104°F (40°C)
- Maximum relative humidity of 80% up to 88°F (31°C) decreasing linearly to 50% @ 104°F (40°C)
- Pollution degree 2 per IEC 664
- Installation Category II

CAUTION: If this equipment is used in a manner not specified by the manufacturer, the protection provide by the equipment may be impaired.

Operation

When the wrist strap tester's power supply is plugged into a grounded outlet the red LED will be on, indicating that the unit is powered. The utility ground is internally connected to the 0.395" (10mm) snap stud on the back of the unit and to the 2 banana jacks at the bottom edge of the tester.

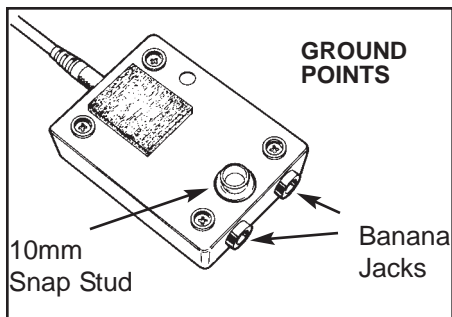

Figure 6. Ground points.

A wrist strap is plugged into one of the banana jacks or into any common grounding point. When the wearer of a wrist strap touches the metallic test surface, the green "test good" LED will light if the operator-to-ground resistance is between 750k Ohms and 10 Megohms.

Proper Ground

The integrity of the utility ground must be tested before the wrist strap tester is plugged in. The wrist strap tester utilizes the "green wire" ground as the static ground. Each outlet must be tested for proper grounding prior to use. Outlets can become ungrounded over

time due to corrosion, wear, or vibration.

ESD Systems.com recommends our model 94380 Ground and Polarity Checker when testing electrical outlets for proper grounding and wiring.

Audible Option

If desired, the wrist strap tester will augment the visual "test good" indicator with an audible signal. To enable/disable the signal, a slide switch is accessible through the hole on the back of the unit.

First, unplug the power supply. Actuate the switch with a small probing tool, being careful to avoid internal damage. In the "on" position, the tester will beep when the green "test good" LED is on, thereby allowing the operator to frequently test the wristband and cord without having to look at the tester.

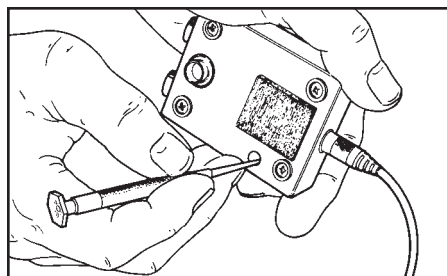

Figure 7. Accessing the audible signal.

Calibration

We recommend annual calibration of our testers. The 41193 is calibrated to NIST traceable standards. Calibration may be performed to insure that the tester is operating within limits.

ESD Systems.com offers a calibration unit that is specifically designed to simplify the calibration procedure. This unit is sold as item 41230. The 41230 comes calibrated to NIST traceable standards. Ask for Tech Brief PS-2006 for detailed procedure to calibrate the 41193. If you are familiar with the procedure, the following resistance should give the display shown:

Resistance Value (+ / - 10%)	Test Output
675k	Red (Low-hazard)
825k	Green (OK-in limits)
8.5 Meg	Green (OK-in limits)
11.5 Meg	Red (High resistance)

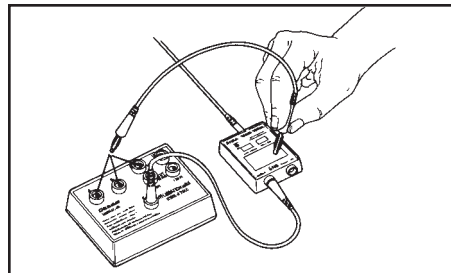

Figure 8. Calibration of tester.

Limited Warranty

ESD Systems.com expressly warrants that for a period of one (1) year from the date of purchase, our Touch Testers will be free of defects in material (parts) and workmanship (labor). Within the warranty period, a unit will be tested, repaired or replaced at our option, free of charge. Call Customer Service at 508-485-7390 for a Return Material Authorization (RMA) and proper shipping instructions and address. You should include a copy of your original packing slip, invoice, or other proof of purchase date. Any unit under warranty should be shipped, prepaid to the ESD Systems.com factory. Warranty repairs will take approximately two weeks.

If your unit is out of warranty, ESD Systems.com will quote repair charges necessary to bring your unit to factory standards. Call Customer Service at 508-485-7390 for a Return Material Authorization (RMA) and proper shipping instructions and address.

Warranty Exclusions

THE FOREGOING EXPRESS WARRANTY IS MADE IN LIEU OF ALL OTHER PRODUCT WARRANTIES, EXPRESSED AND IMPLIED, INCLUDING MERCHANTABILITY AND FITNESS FOR A PARTICULAR PURPOSE WHICH ARE SPECIFICALLY DISCLAIMED.

The express warranty will not apply to defects or damage due to accidents, neglect, misuse, alterations, operator error, or failure to properly maintain, clean or repair products.

Limit of Liability

In no event will ESD Systems.com or any seller be responsible or liable for any injury, loss or damage, direct or consequential, arising out of the use of or the inability to use the product. Before using, users shall determine the suitability of the product for their intended use, and users assume all risk and liability whatsoever in connection therewith.

 **ESD SYSTEMS.com**

432 NORTHBORO ROAD CENTRAL
MARLBORO, MA 01752-3170
PHONE (508) 485-7390
FAX (508) 480-0257