

©COPYRIGHT 1989
MILLER FREEMAN PUBLICATIONS, INC.
ALL RIGHTS RESERVED

THIS ARTICLE APPEARED IN THE FEB./MARCH ISSUE OF *EOS/ESD TECHNOLOGY*. IT HAS BEEN REPRINTED WITH PERMISSION OF MILLER FREEMAN PUBLICATIONS, 1050 COMMONWEALTH AVE., BOSTON, MA 03215.

SAFE GROUNDING OF STATIC-CONTROLLED WORKSTATIONS

Although ESD-protective grounding is often crucial, it is far from the only consideration in workstation grounding; the avoidance of shock hazard to personnel is even more important.

By Edward H. Russell

Member, ESD Assn. Grounding Standards Subcommittee, and Quality Assurance Specialist, Santa Barbara, CA

The term "grounding" is often misunderstood; it's used freely and often without the necessary modifying specifics. That's unfortunate because unless grounding is understood and its principles properly applied, an improperly grounded workstation not only can allow damage to sensitive parts, but can present a shock hazard to humans as well.

There are various concepts of grounding. Some authorities relate it to a connection with the earth, while

others speak in terms of a common point to which all electrical returns are connected.

In electronics, different grounds may exist. Electromagnetic, electrostatic, signal, chassis and power grounds may be addressed separately in order to control noise, interference, and undesirable current flow.

In geographic areas where electrical storms are intense, special rods are installed on buildings to divert lightning to earth through heavy-gauge wire. A similar

configuration is used in electrical power systems. The National Electrical Code recommends that the neutral circuit of all AC systems be terminated in some conducting body in the earth. Here's why: such a grounding system...

1. Maintains an arbitrary zero voltage reference for the AC system;
 2. Protects a building from lightning;
 3. Drains equipment's static charge.
- Fig. 1 shows how earth grounding is configured in a typical 120-V, 60-Hz electrical system. This type of system is the one most commonly used at workstations in industry today and is, therefore, a primary subject of this article.

An ESD Ground?

One might think that electrical system grounds should not be used for ESD-protective grounding, but this is not necessarily the case. A frequent alternative to using the system ground for ESD is a separate earth ground rod installed near the workstation for ESD use, and this is indeed effective in draining away static charges. However, such a ground can be hazardous to personnel working near electrical equipment; such a situation could allow a potential difference between equipment and the separate ESD ground.

In addition to personnel hazards, an electrical overstress (EOS) hazard might exist between, say, a soldering iron (grounded through the power system) and a worksurface using the separate ESD ground described above. Fig. 2 illustrates the potential problems.

Obviously, this is undesirable both for people and parts. However, a properly grounded piece of electrical equipment placed on a grounded worksurface reduces this hazard. However, there is still the possibility of ground current flowing through the worksurface itself, and static charges might not bleed off

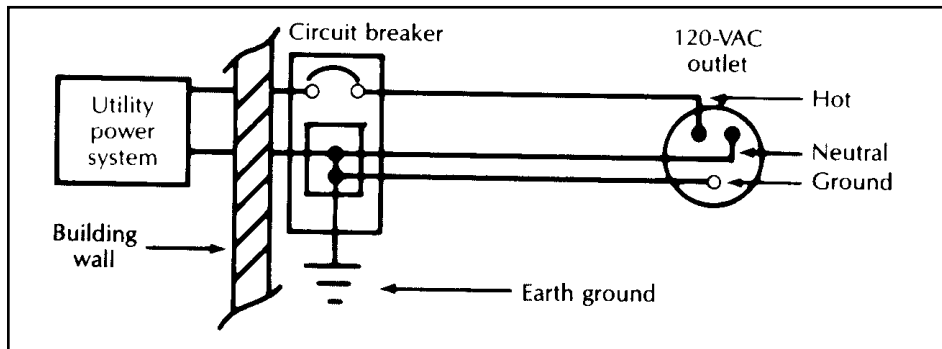
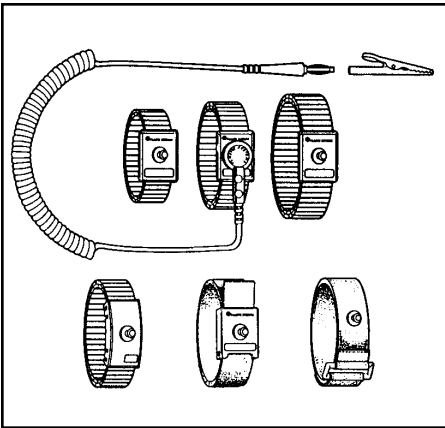

Figure 1. Earth grounding in a typical 120-V, 60-Hz electrical system

Industrial Grade Wriststraps



We make our wriststraps with the industrial environment in mind. They are designed and manufactured to give you years of service in the tough electronic assembly environment.

May we send you a sample?

Quality Ground Cords

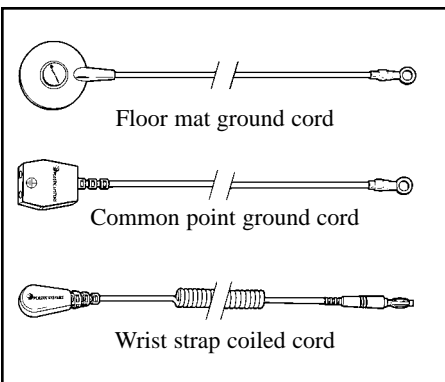

For the highest quality ground cords for mats, work surfaces, and equipment call ESD Systems. Ask for a sample.

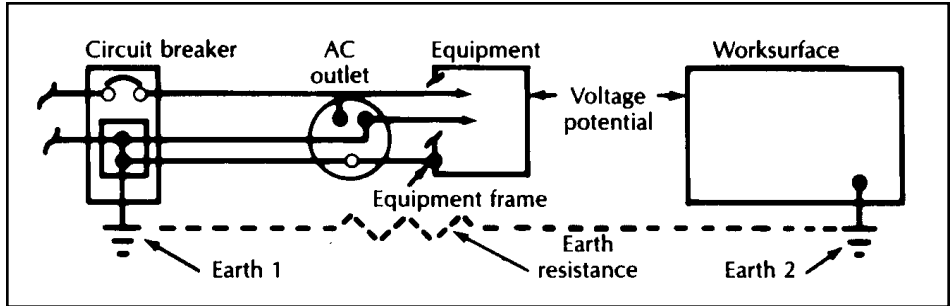

Figure 2. Separate ground systems present potential problems.

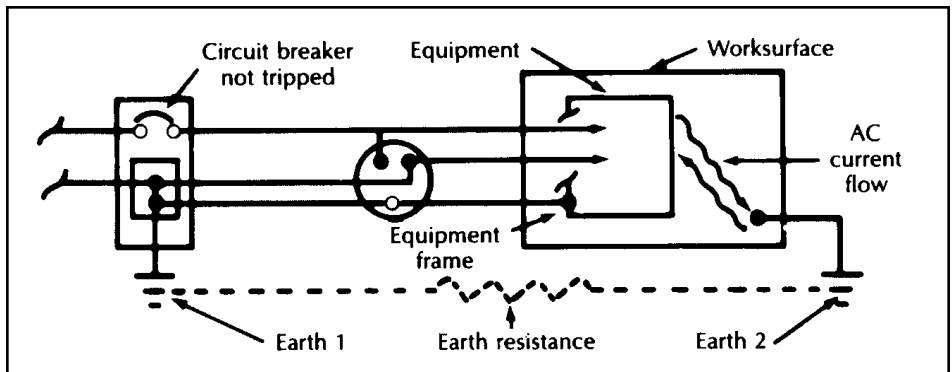

Figure 3. How current flow through a work surface is generated.

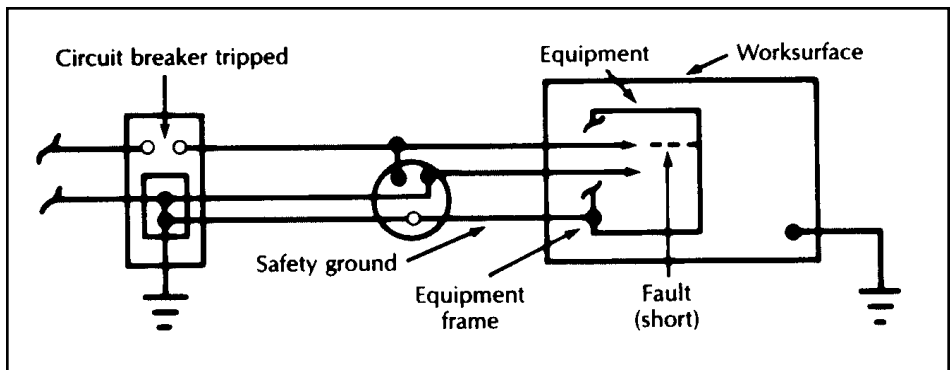

Figure 4. The relationship between equipment (or safety) ground and earth ground.

completely due to related effects. Fig. 3 shows how current flow through the work surface is generated.

This problem can be solved by bonding the two earth grounds together, eliminating the resistance between them. If electrical power is nearby or incorporated in workstations, work surface and wrist-strap ground circuits should be connected only to the electrical-power-system ground to minimize potential differences.

An equipment ground conductor is often used in case a fault develops in the primary power-system ground. Fig. 4 shows the relation between equipment ground (also referred to as safety ground) and earth ground. This methodology is designed to handle situations in which 120-V power accidentally contacts the frame of electrical equipment. So-called fault current will flow through the equipment ground, triggering the local circuit breaker. Installation of Ground Fault Circuit Interrupters, or GFCIs, increases safety further.

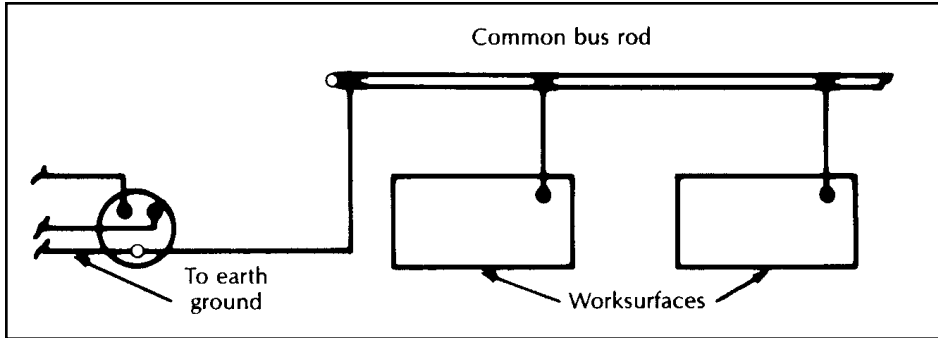

Figure 5. Grounding strategy for workstations without AC power.

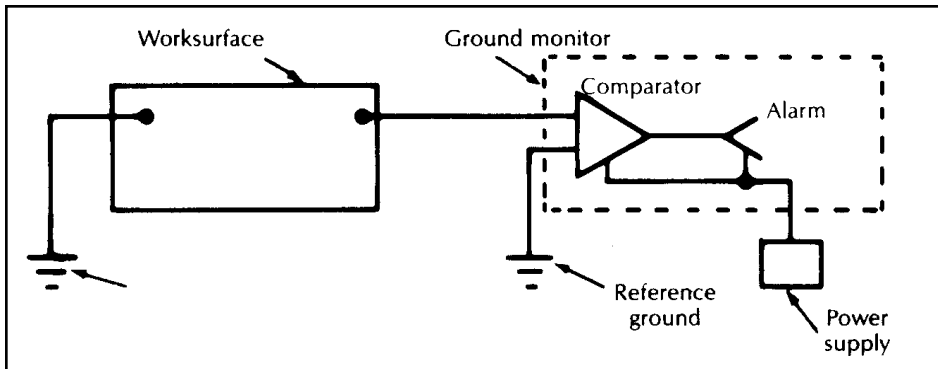

Figure 6. Block diagram of a ground-integrity monitor.

Testing Is a Must

Electrical systems should always be tested before depending on a grounding system. Accurate, reasonably priced and easily operated systems analyzers are available. The analyzer used should both detect flaws in the system and also verify the wiring configuration per the National Electrical Code. Electricians aren't needed for these tests unless discrepancies are noted.

To maximize safety, the analyzer should be able to detect flaws such as an equipment ground shorted to neutral in the AC outlet box. It should also be capable of testing equipment-ground impedance by injecting AC current into the equipment-ground conductor and measuring between it and the neutral conductor. ECOS Corp. (Oak Park, IL, Phone 208-383-2525, Fax 208-383-2137), a consultant on AC distribution and grounding, recommends 1 Ω between ground and neutral.

Doing It Yourself

Though it should rarely be necessary, there are adequate means of measuring earth-ground resistance in AC systems. Install a 5/8-in. by 6-ft. copper rod in the earth near an electrical circuit. Using a specialized ground-resistance tester, measure the earth's resistance between your auxiliary earth ground and the AC system's ground conductor. Ordinary meters are not recommended for this measurement due to the possibility of invalid measurements; ground-resistance testers can guard against earth currents (and consequent measurement inaccuracies); the typical VOM cannot.

The resistance will vary depending on the nature and moisture of the soil and the physical implementation of the system ground. For ESD purposes, the maximum resistance allowable for rapid static decay is about 1 M Ω however, if the AC system ground meets Code requirements, the resistance should measure less than 100 Ω .

Wriststrap Ground

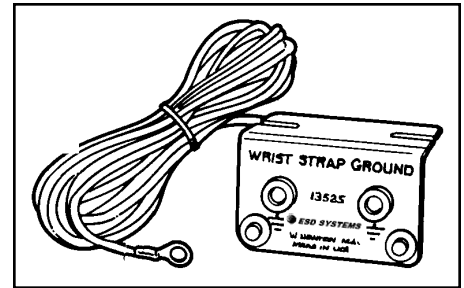

Item No. 13525 provides a secure ground at each work station, and comes complete with grounding wire and instructions.

Quad Common Point Ground

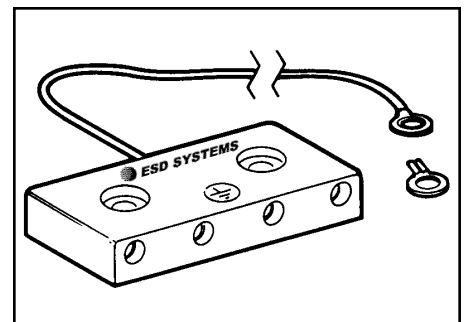

Item No. 13575 is designed for use as either a multiple grounding block or as a common point ground cord.

Grounds Mats, Grounds Wriststraps, and Tests at a Touch

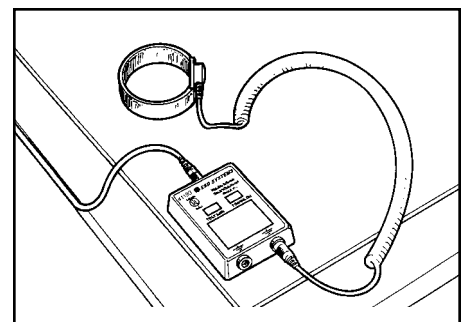

Item No. 41193 is a wriststrap tester that also grounds your mat. Call us if you would like to see one.

Powerless...

Workstations without AC power can be grounded to a common bus rod mounted near the workstations. Their worksurfaces should be connected to the ground bus with wire of 20-gauge minimum diameter and preferably larger. Heavy stranded wire may be preferable to a less-durable solid-conductor. The end of this grounding bus should be bonded to a convenient AC-

equipment-ground circuit. This type is shown in Fig. 5.

Equipment-ground conductors in workstations wired with 120-VAC can be used for grounding, provided the circuit has been tested and has passed. In addition, the equipment-ground circuit should be bonded electrically to a workstation's metal frame if that frame is to be used as common-ground point.

Continuity of less than 1 Ω can be measured with the wiring analyzer(s) previously described. If a workstation frame's resistance is too high, an approach similar to that shown in Fig. 5 should be used. In any event, for added safety, such metal frames should always be bonded securely to the equipment ground.

ESD Systems Makes Grounding of Work Surfaces and Floor Mats Fast and Easy

Our complete line of field installable snaps makes grounding a "snap". Now you can place your single ground point any place on your work surface or floor mat.

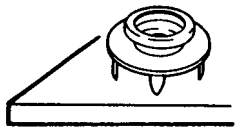

Installing push and clinch snap for use with multi layer or soft conductive mats Item No. 12102

Universal Screw-on Kit Item No. 12000

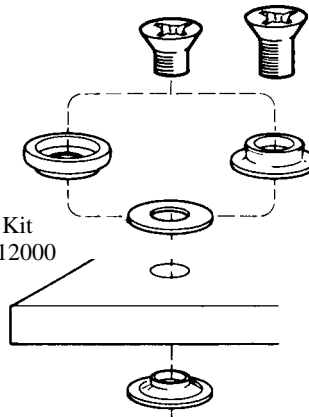

Our common point ground cords and testers allow for "common point grounding".

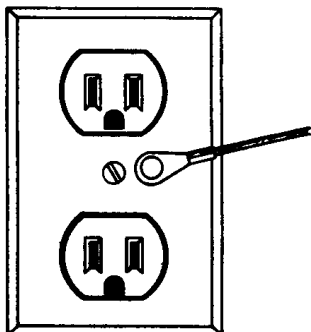
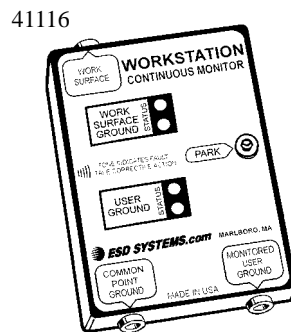
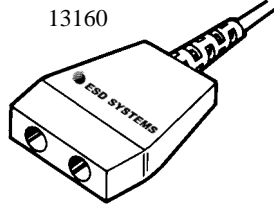
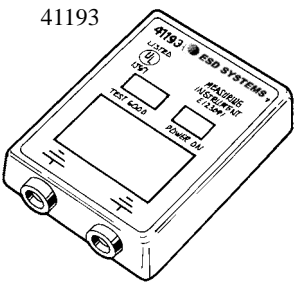

Our ground cords are designed to hook directly onto any nearby "green wire" utility ground.

Ask for Tech Brief PS-2013 for details on proper grounding and installation of ESD protective surfaces or PS-2017 for proper maintenance and grounding of wrist straps.



Visit our online library of Tech Briefs:
<http://www.esdsystems.com/>

Monitoring

To ensure the continuing safety of people and ESD-sensitive electronics, all static-controlled workstations should be periodically tested for ground integrity. However, even periodic testing can't detect an immediate break or degradation in a grounding circuit. When such a break is eventually uncovered, it is often too late for some parts, thus various constant monitoring systems are available. Figure 6 shows a block diagram of such a monitor. These monitors sound an alarm if an open circuit of ground-circuit degradation occurs. Unfortunately, some of these monitors are undependable, so it's good policy to periodically test not only ground integrity but the associated monitors as well.

1. C.C. Kleronomos and E.C. Cantwell, "A Practical Approach to Establish Effective Grounding for Personnel Protection," *IEEE IAS Annual Conference Record*, 1979.
2. R.H. Lee, "Electrical Safety in Industrial Plants," *IEEE Spectrum*, June 1971.
3. C.F. Daziel, "Electrical Shock Hazard," *IEEE Spectrum*, February 1972.
4. National Electrical Code.
5. E.H. Russell, "Static-Safe Worksurfaces and Personnel Safety - Update," *Evaluation Engineering*, September 1986.
6. E.H. Russell, "Safely Grounding Static-Control Worksurfaces," *EOS/ESD Technology*, June 1987.

ESD SYSTEMS.com

432 NORTHBORO ROAD CENTRAL,
MARLBORO, MA 01752-3170
PHONE (508) 485-7390
FAX (508) 480-0257