



Made in America

Universal Remote Operation, Installation, and Maintenance



Figure 1. EMIT Universal Remote

Description

The EMIT Universal Remote provides an ESD wrist strap ground point for dual-wire wrist straps when the included ground wire is attached to equipment ground. The Universal Remote is designed to be used with EMIT, Desco, Semtronics and 3M dual-wire wrist strap/continuous monitor systems that terminate with a 3.5 mm mono plug. Included is a parking station which stores and protects the wrist strap cord when not attached to the operator.

Two screws are provided to mount the Universal Remote in the most productive and convenient location; typically under the workbench top, thus not utilizing any worksurface area. The construction is rugged and durable.

The EMIT Universal Remote is available in two models:

Item	Monitor Counterpart(s)
50541	EMIT Zero Volt Monitor
50542	EMIT Dual Operator Programmable Monitor, 3M 724 Monitor

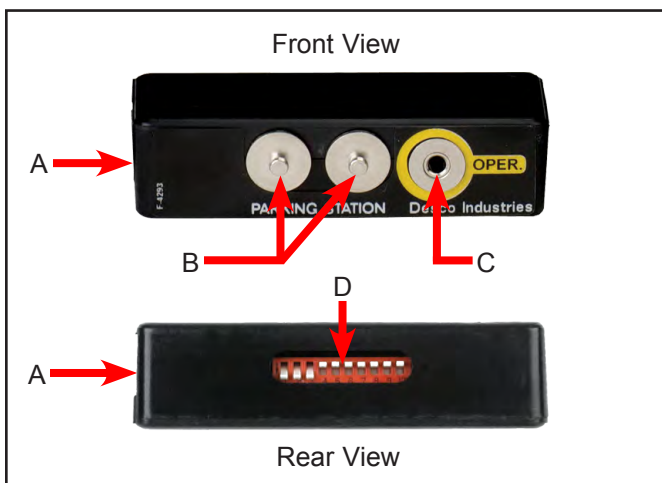

Figure 2. Universal Remote features and components

Packaging

- 1 Universal Remote
- 1 RJ45 to RJ11 Modular Cable (50541)
- 1 RJ11 to RJ11 Modular Cable (50542)
- 2 Screws

Features and Components (See Figure 2)

A. RJ11 Modular Jack: Insert the RJ11 plug end of the included modular cable here. The other end of the cable connects to the monitor.

B. 4mm Parking Station: Park coil cord here when not using the monitor.

Use the parking station to prevent wrist straps from being:

- removed from the workstation
- lost
- dropped and damaged when not in use

C. 3.5mm Dual-Wire Operator Jack: Insert dual-wire coil cord's 3.5mm mono plug here.

D. DIP Switches: Settings may be modified to allow compatibility for different monitors (see Figure 3).

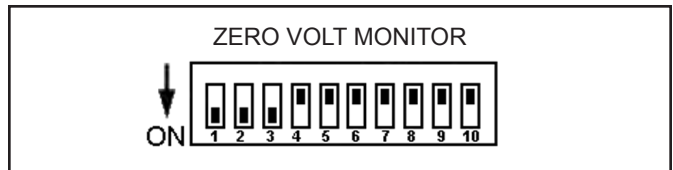

Figure 3. 50541 Universal Remote DIP switch settings

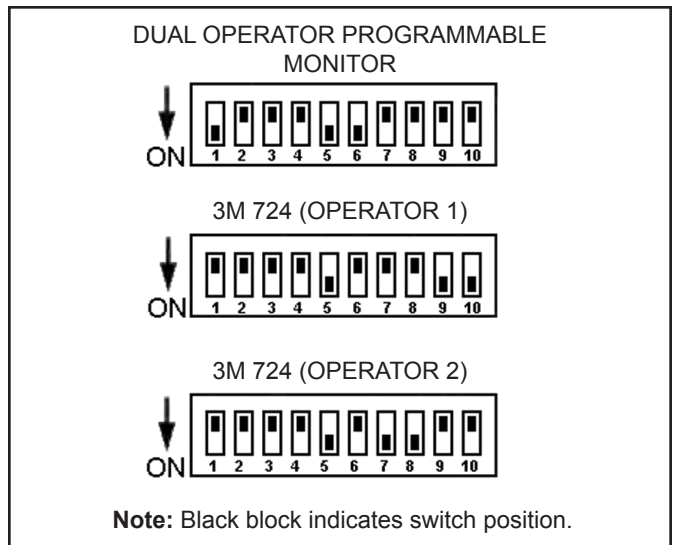

Figure 4. 50542 Universal Remote DIP switch settings

Installation

Remove the Universal Remote from its packaging and inspect for any shipping damage. Modify the remote's DIP switch settings to match with its corresponding monitor (see Figures 3 and 4). The improved 4mm snaps give the operator the option of using the Jewel® Dual-Wire Coil Cord or Jewel® MagSnap Dual-Wire Coil Cord (with adapters). Decide on a convenient location to mount the remote; it is typically mounted under the workbench top to save workspace.

Note: Ensure that the distance between the monitor and remote does not exceed the reach of the included modular cable.

Use the included screws to mount the remote on the decided location.

CONNECTING TO ZERO VOLT MONITOR:

1. Turn the monitor off by disconnecting the power cord from the power jack located on the back of the monitor.
2. Insert the RJ45 plug end of the included modular cable into the OP1 or OP2 modular jack located on the back of the monitor.
3. Route the other end of the cable to the Universal Remote. Insert the RJ11 plug into the modular jack located on the side of the remote.
4. If connecting another Universal Remote to the Zero Volt Monitor, repeat Steps II and III.
5. Reconnect the power cord to the monitor once all connections have been made.

CONNECTING TO DUAL OPERATOR PROGRAMMABLE RESISTIVE LOOP WORKSTATION MONITOR:

1. Turn the monitor off by disconnecting the power cord from the power jack located on the back of the monitor.
2. Insert one end of the included modular cable into the OP1 or OP2 modular jack located on the back of the monitor.
3. Route the other end of the cable to the Universal Remote and insert the plug into the modular jack located on the side of the remote.
4. If connecting another Universal Remote to the Dual Operator Programmable Resistive Loop Workstation Monitor, repeat Steps II and III.
5. Reconnect the power cord to the monitor once all connections have been made.

CONNECTING TO 3M 724 MONITOR:

1. Turn the monitor off by disconnecting the power cord from the power jack located on the back of the monitor.
2. Insert one end of the included modular cable into the 732 (operator 1) or 733 (operator 2) modular jack located on the back of the monitor.

3. Route the other end of the cable to the Universal Remote and insert the plug into the modular jack located on the side of the remote. Note: If connected to the 732 jack, ensure that the remote's DIP switch settings match those of "3M 724 (OPERATOR 1)" in Figure 3. If connected to the 733 jack, ensure that the remote's DIP switch settings match those of "3M 724 (OPERATOR 2)" in Figure 3.
4. If connecting another Universal Remote to the 3M 724 Monitor, repeat Steps II and III.
5. Reconnect the power cord to the monitor once all connections have been made.

Operation

Remove the charges from your body by making contact with a properly grounded ESD worksurface. Snap the wrist cord to the wristband, and fit it snugly onto your wrist. Insert the the mono plug at the other end of the wrist cord into the Universal Remote's operator jack.

PARKING STATION

Disconnect the wrist cord from your wrist strap and park it on the Universal Remote's parking station to promote better wrist cord storage.

TO USE THE CONTINUOUS MONITOR:

See the monitor's operation instructions.

Specifications:

Operating Temperature	0 - 40°C
Size	1.22"L x 3.22"W x .85"H

Limited Warranty

EMIT expressly warrants that for a period of five (5) years from the date of purchase EMIT Universal Remotes will be free of defects in material (parts) and workmanship (labor). Within the warranty period, a credit for purchase of replacement EMIT Universal Remotes, or, at EMIT's option, the Universal Remote will be repaired or replaced free of charge. If product credit is issued, the amount will be calculated by multiplying the unused portion of the expected five year life times the original unit purchase price. Call our Customer Service Department at 909-664-9980 for a Return Material Authorization (RMA) and proper shipping instructions and address. Please include a copy of your original packing slip, invoice, or other proof of date of purchase. Any unit under warranty should be shipped prepaid to the EMIT factory. Warranty replacements will take approximately two weeks.

If your unit is out of warranty, call our Customer Service Department at 909-664-9986 for a Return Material Authorization (RMA) and proper shipping instructions and address. EMIT will quote repair charges necessary to bring your unit up to factory standards.

Warranty Exclusions

THE FOREGOING EXPRESS WARRANTY IS MADE IN LIEU OF ALL OTHER PRODUCT WARRANTIES, EXPRESSED AND IMPLIED, INCLUDING MERCHANTABILITY AND FITNESS FOR A PARTICULAR PURPOSE WHICH ARE SPECIFICALLY DISCLAIMED. The express warranty will not apply to defects or damage due to accidents, neglect, misuse, alterations, operator error, or failure to properly maintain, clean or repair products.

Limit of Liability

In no event will EMIT or any seller be responsible or liable for any injury, loss or damage, direct or consequential, arising out of the use of or the inability to use the product. Before using, users shall determine the suitability of the product for their intended use, and users assume all risk and liability whatsoever in connection therewith.